

# Designa CONNECT GATE XL 600

Reliable and energy-saving barrier in modern design combined with state-of-the-art control technology.

The robust and high-quality barrier was developed according to the latest standard, especially for parking management systems and offers high functionality.

## FEATURES

- Barrier arm length up to 6.3 m
- Opening and closing in 4 sec. as standard
- Adjustable opening and closing speeds
- Compact control unit with versatile configuration options
- Innovative motor technology with high energy efficiency
- Various interfaces for modern control technology
- Boost function for detection of vehicles with high ground clearance, e.g. SUV, or vehicles with trailers
- TFT colour display (18.5") for displaying digital content (optional)
- Maintenance-friendly due to modular design
- Easy assembly and installation
- Approval for high wind loads
- For almost all standard passenger cars

## BASIC EQUIPMENT

### Casing

- Best possible corrosion protection
- Stable construction

### Drive Unit

- Brushless DC servomotor, wear resistant, resilient and maintenance free
- High energy efficiency
- Outstanding longevity
- Compact motor and gear unit
- Fast response time
- Non-contact reversing mechanism
- Adjustable opening and closing speeds

### Barrier arm

- Standard barrier arm, mounted right hand side, barrier arm lengths: 4.3 m, 5.3 m, 6.3 m
- Pendulum support or support stanchion required from a blocking width of 4 m (option)

## CONTROL UNIT

- Interfaces for modern control technologies
- Integrated two-channel induction loop detector
- Simple parameterising due to operating keys or configuration tool via PC
- Extensive configuration options
- Automatic frequency settings of the detectors
- Boost function (ASB) for automatic sensitivity increase when detecting vehicles with high ground clearance
- Configurable behaviour in case of power outage:
  - Barrier gate opens automatically after power outage<sup>1</sup>
  - Barrier gate remains closed and locked
  - Barrier gate remains closed and unlocked

<sup>1</sup>only for barrier arm length up to 3.7m

## OPTIONS

- Barrier arm mounted left hand side
- Pendulum support or support stanchion
- Electromechanical arm blockage with control unit
- Light barrier, reflective or light sensor
- TFT colour display (18.5") for the display of digital content, e.g. dynamic price development, occupancy data, routing or advertising
- Ultrasonic sensor
- Key switch
- Fire brigade switch
- Additional external double detector for induction loops
- Radio remote control
- 2 terminals controlling one barrier for the operation of one barrier from two control devices
- Thermostatically regulated heater
- Surge arrester
- Installation of a relay
- Red LED warning light
- Yellow LED signal light
- Red LED flashing light
- Special customised colour
- Ram protection rail or posts
- Foundation frame/mounting kit

## DESIGN

- Casing, door and cover made of stainless steel 1.4016, base frame made of stainless steel 1.4301 (V2A), outer and inner surface with durable, weather-resistant powder coating
- Casing body and door: RAL 9016 (traffic white)
- Cover: RAL 9017 (traffic black)
- Casing door secured with a cylinder lock
- Barrier arm made of octagonal aluminium profile, weather-resistant white coated, with red reflective stripes, lower edge with shock-absorbing edge protector

## FIGURE, DIMENSIONS IN MM

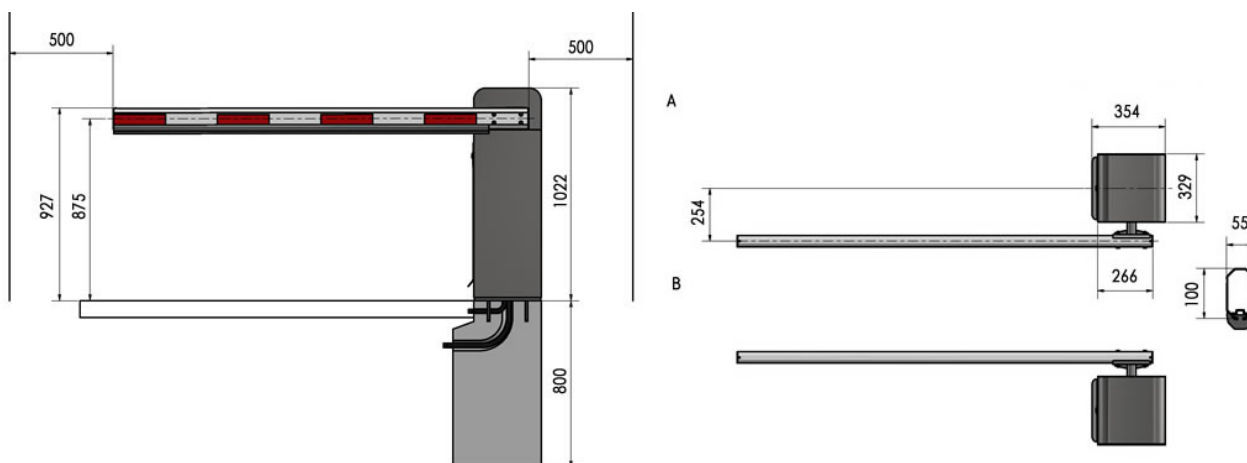

## TECHNICAL DATA

- Type: GATE2-P4000
- Power supply: 100-240 V AC, 50 Hz
- Current consumption (power supply 230 V AC, 50 Hz): 0,25 A
- Current consumption with activated optional heater and other options: max. 6 A
- Power consumption (power supply 230 V AC, 50 Hz): max. 25 W
- Power consumption with activated optional heater: approx. 500 W
- Network system: TN-S system
- Pre-fuse: max. 16 A
- Terminal cross-section: max. 2.5 mm<sup>2</sup>
- Connection type: tension spring connection
- Protection class: I
- Control voltage: 24 V DC
- Ingress protection rating: IP 54
- Temperature:
  - operation: -20 C to +50°C
  - with heater: -30 C to +50°C
  - storage: -30 C to +70°C
- Barrier arm length: max. 6.3 m
- Weight: 50 kg, without the barrier arm
- Dimensions: see figure

## SAFETY/ REGULATIONS

- CE Declaration of Conformity in accordance with Machinery Directive 2006/42/EC, EMC 2014/30/EU and Construction Product Regulation 305/2011

## CONTACT

DESIGNA Verkehrsleittechnik GmbH  
 Faluner Weg 3  
 24109 Kiel, Germany  
 info@designa.com  
 T: +49 (0) 431 5336-0  
 F: +49 (0) 431 5336-260