

Designa CONNECT GATE 600

Reliable and energy-saving gate in modern design combined with state-of-the-art control technology. The robust, high-quality gate has been developed according to the latest parking management standards.

FEATURES

- Various gate arm length: max. 12 feet (3.7 m).
- Adjustable opening and closing speeds from 1.3 to 2.5 sec.
- Compact control unit with versatile configuration options.
- Innovative motor technology with high energy efficiency.
- Various interfaces for modern control technology.
- Boost function for detection of vehicles with high ground clearance, e.g. SUV, or vehicles with trailers.
- TFT color display (18.5") for displaying digital content (optional).
- Maintenance-friendly, modular design.
- Easy assembly and installation.
- Approval for high wind loads.

BASIC EQUIPMENT

Housing

- Market leading corrosion protection.
- Robust construction.

Drive Unit

- Brushless DC servomotor, durable and maintenance free.
- High energy efficiency.
- Outstanding longevity.
- Compact motor and gear unit.
- Fast response time.
- Auto-reverse functionality.
- Adjustable opening and closing speed.

Gate arm

- Standard gate arm: 9 feet (2.7 m), mounted right hand side.
- Alarm message for misaligned/broken gate arm.

CONTROL UNIT

- Interfaces for modern control technologies.
- Integrated two-channel induction loop detector.
- Simple operating using PC function keys or configuration tool.
- Extensive configuration options.
- Automatic frequency settings.
- Boost function for automatic sensitivity increase to detect and confirm high ground clearance vehicles.
- Choose from various power outage behavior options:
 - gate opens automatically.
 - gate remains closed and locked.
 - gate remains closed and unlocked.

OPTIONS

- Straight gate arm: max. 12 feet (3.7 m)
- Articulated gate arm: max. 10 feet (3 m)
- Illuminated straight gate arm: max. 12 feet (3.7 m)
- Illuminated articulated gate arm: max. 8.5 feet (2.7 m)
- Gate arm mounted left hand side.
- Light barrier, reflective or light sensor.
- TFT color display (18.5") for the display of digital content, e.g. dynamic price development, occupancy data, routing or advertising.
- Ultrasonic sensor.
- Key switch.
- Fire department switch.
- Additional dual sensor for induction loops.
- Two control devices for one gate.
- Thermostatically regulated heater.
- Surge arrester.
- Installation of a relay.
- Various terminal colors are available.
- Ram protection rail or posts.
- Foundation frame/mounting kit.

DESIGN

- Housing, door and cover made of stainless steel 1.4016, base frame made of stainless steel 1.4301 (V2A), outer and inner surface with durable, weather-resistant powder coating.
- Housing body and door: RAL 9016 (traffic white).
- Cover: RAL 9017 (traffic black).
- Cylinder lock secured front panel.
- Gate arm made of aluminum profile, anodized colorless, with red reflective stripes, lower edge with shock-absorbing edge protection.

DRAWING, DIMENSIONS IN INCH (MM)

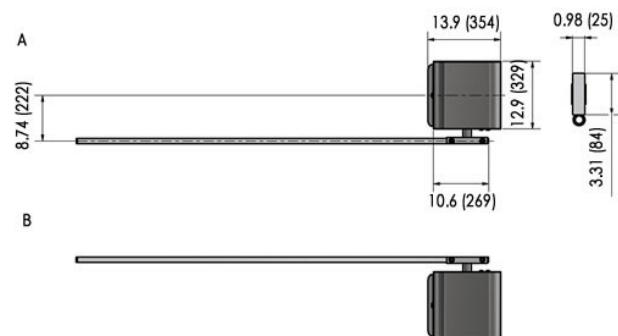
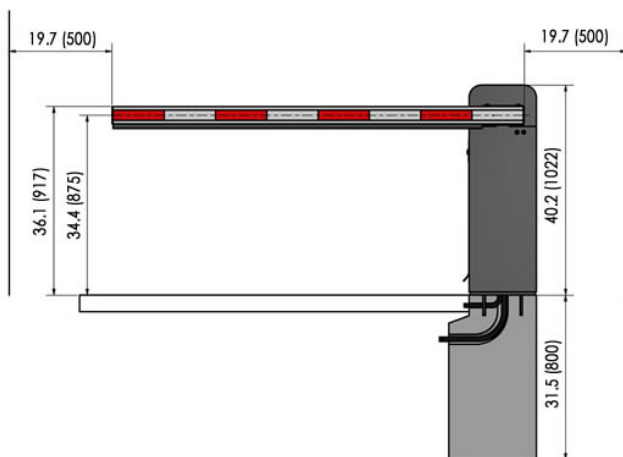

TECHNICAL DATA

- Type: GATE2-P1300
- Power supply: 100-240 V AC, 50/60 Hz
- Current consumption (power supply 120 V AC, 60 Hz): 1.5 A
- Current consumption with activated optional heater and other options: max. 7.5 A
- Power consumption (power supply 120 V AC, 60 Hz): max. 90 W
- Power consumption with activated optional heater: approx. 500 W
- Network system: TN-S system
- Pre-fuse: max. 16 A
- Terminal cross-section: max .AWG 12
- Connection type: tension spring connection
- Protection class: I
- Control voltage: 24 V DC
- Ingress protection rating: IP 54
- Temperature:
 - operation: -4 F to 122 F (-20 C to +50°C)
 - with heater: -22 F to +122 F (-30 C to +50°C)
 - storage: -22 F to 158 F (-30 C to +70°)
- Barrier arm length: max. 12 feet (3.7 m)
- Weight: 110 lbs (50 kg), without the gate arm
- Dimensions: see figure

CERIFICATION



- UL File Number: E198104

CONTACT

DESIGNA Access Corporation
 777 Oakmont Lane, STE 2000
 Westmont, Illinois 60559
 Phone +1 (630) 891-3038
 sales.usa@designa.com
 https://us.designa.com